

HEPA Series

Air Filtration System



Your Fantech HEPA Filtration system should be installed in conformance with the appropriate local, provincial or state requirements or in the absence of such requirements with the current edition of the National Building Code, and / or ASHRAE's " Good Engineering Practices".

United States





10048 Industrial Blvd., Lenexa, KS, 66215
Tel.: 800.747.1762 • Fax: 800.487.9915

Canada

50 Kanalfakt Way, Bouctouche, NB, E4S 3M5
Tel.: 800.565.3548 • Fax: 877.747.8116

Fantech reserves the right to modify, at any time and without notice, any or all of its products' features, designs, components and specifications to maintain their technological leadership position.
Please visit our website www.fantech.net for more detailed technical information.



				
Note	Warning/ Important note	Information	Technical information	Practical tip



PLEASE READ THIS MANUAL BEFORE INSTALLING UNIT

Before installation, careful consideration must be given to how this system will operate if connected to any other piece of mechanical equipment, i.e. a forced air furnace or air handler, operating at a higher static pressure.



Products are designed and manufactured to provide reliable performance, but they are not guaranteed to be 100% free of defects. Even reliable products will experience occasional failures, and this possibility should be recognized by the user. If these products are used in a life support ventilation system where failure could result in loss or injury, the user should provide adequate back-up ventilation, supplementary natural ventilation or failure alarm system, or acknowledge willingness to accept the risk of such loss or injury.

Your Fantech HEPA Filtration system should be installed in conformance with the appropriate local, provincial or state requirements or in the absence of such requirements with the current edition of the National Building Code, and / or ASHRAE's " Good Engineering Practices".

Table of content

INTRODUCTION	4
DIMENSIONS	4
SPECIFICATIONS	4
OPERATION	4
INSTALLATION	5
CM 3000 – Uninsulated model	
Option A	5
Option B	5
Option C	5
Option D	6
CM 3000 I – Insulated model	
Option A	7
Option B	7
Option C	8
Option D	8
Whole House – Connecting a ventilation system (HRV/ERV) to HEPA system	9
SERVICE	10
PARTS LIST	10
MAINTENANCE SCHEDULE	11

Introduction

HEPA Air Filtration Systems

You have purchased a very effective air cleaning and treatment system incorporating HEPA (High Efficiency Particulate Arrestance) filter technology. This is the type of air cleaning equipment that respiratory specialists recommend most. To optimize the performance of your HEPA Filtration System, it should be installed by a professional contractor who is familiar with your indoor air quality situation and the operation of other heating, ventilation and air conditioning equipment that you may have.

Two Units to Choose From

The Fantech HEPA Filtration system is available in two different models, depending on your choice of installation. Typically the CM 3000 is used in geographical locations where the HEPA unit can be installed in a conditioned space such as a basement, closet or heated crawl space, (Example on page 5 & 6). The CM 3000 I (Insulated version) is normally installed in the southern U.S. states where it's common to locate the HVAC equipment in an unconditioned space such as a garage or attic (Example on pages 7 & 8).

Dimensions

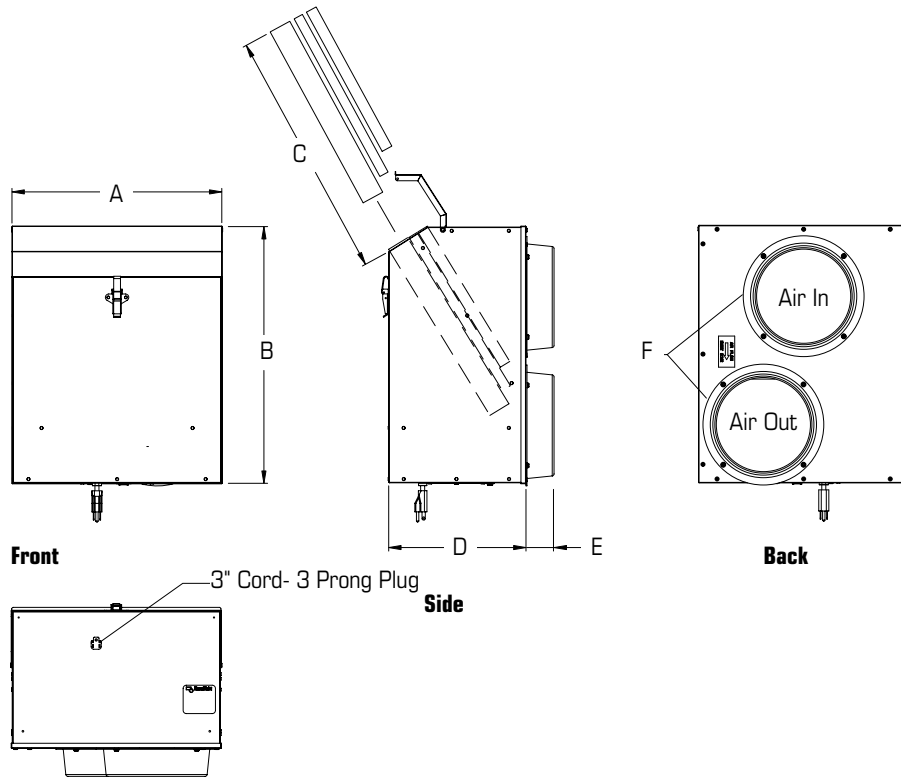

Model	A		B		C*		D		E		F Duct Size		Voltage	Amp	Delivery
	in	mm	in	mm	in	mm	in	mm	in	mm	in	mm	V	Amps	cfm
CM 3000	16 4/5	418	20	508	16 1/2	420	10 11/16	272	2 3/10	55	8	203	115/V1/60	1	240
CM 3000 I	18 3/5	434	22 3/10	524	16 1/2	420	13	288	2 3/10	55	8	203	115/V1/60	1	240

* Clearance required for servicing the unit

Specifications

Model CM 3000 (uninsulated)

Insulated skin can be purchased separately and installed in the field if required

- Kit (included):
- Two pcs. of uninsulated 8" flex (UL Listed)
 - Four 8" round port collar
 - Hanging Chains and hardware
 - Installation manual

Model CM 3000 I (insulated)

- Unit (included):
- Two 8" round port collar
 - Hanging Chains and hardware
 - Installation manual

Operation

Your Fantech HEPA filtration system incorporates three stages of filtration. Air is drawn from the house via one of the installation examples, found in this manual, by a powerful efficient EBM fan. The air is cleaned as it passes through the filters, where it is then reintroduced back into the home, cleaned of the majority of harmful particles.



A semi-annual service schedule must be followed to ensure the HEPA unit is operating at its full potential.

Installation

CM 3000 - Uninsulated model

Option A & B

* Diagrams are examples only. Actual installation may vary.

The return side of the furnace is the recommended location for the HEPA to connect to. The supply side is normally avoided due to the higher static pressure.



Furnace fan should operate continuous or when HEPA unit is on and running. (Options A & B)

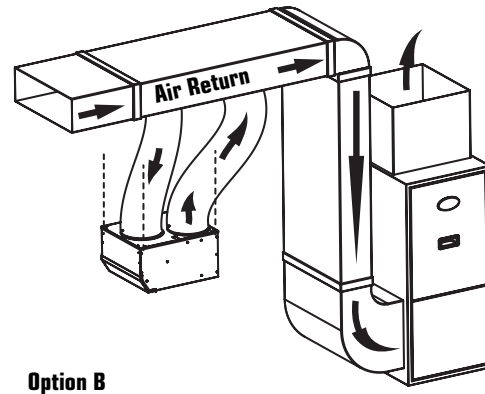
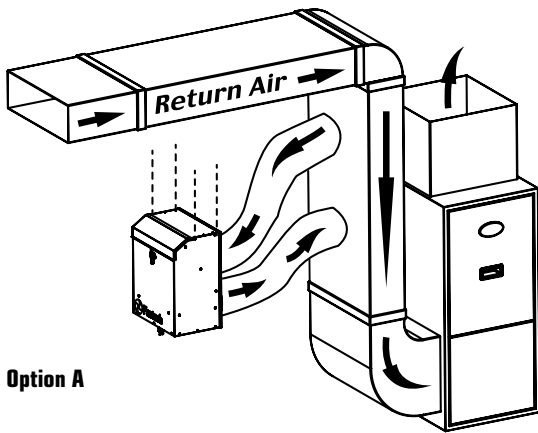

Option C

* Diagrams are examples only. Actual installation may vary.

Duct work can be concealed in walls or closets. If the floor is the only choice, special care should be taken to avoid noise or drafts.

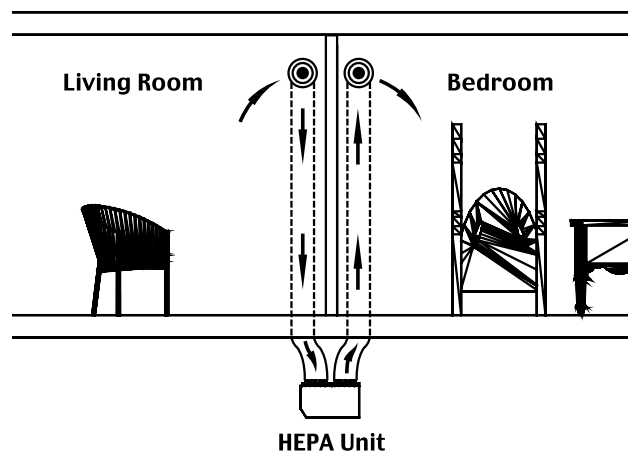

Installation (Cont'd)

Option D

* Diagrams are examples only. Actual installation may vary.

Unit can be installed in a closet. Air drawn from a hallway or living area is cleaned by the HEPA unit and reintroduced back into a bedroom or other room.

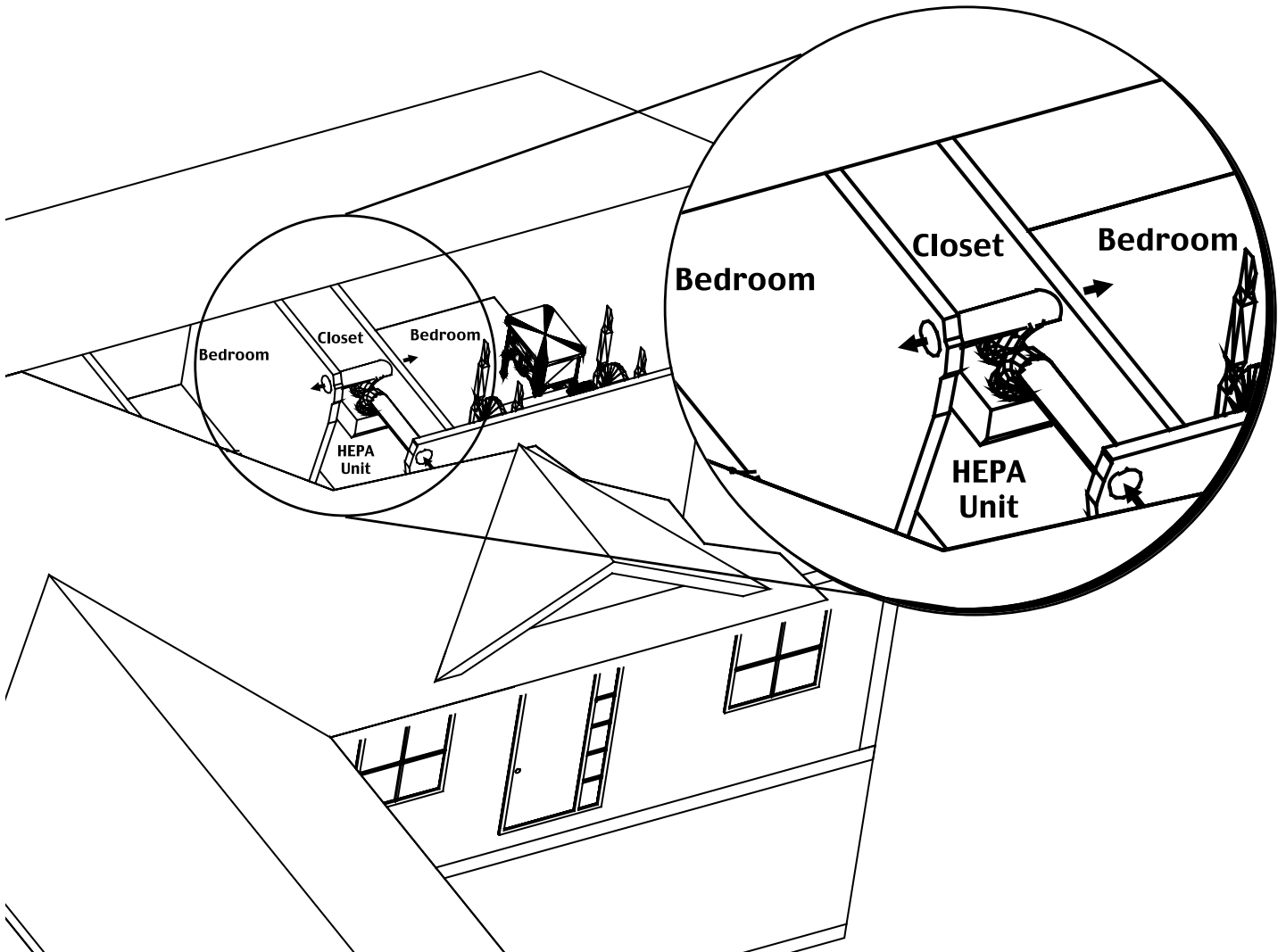

Installation (Cont'd)

CM 3000 I - Insulated model

* Diagrams are examples only. Actual installation may vary.

In options A & B, the air handler should operate continuously or when HEPA unit is on and operating.



Special care and attention must be given to ensure that all openings in unit, and its duct connections, are sealed, to prevent vehicle exhaust from entering the unit. Always follow local and state building codes as well as good engineering practices.

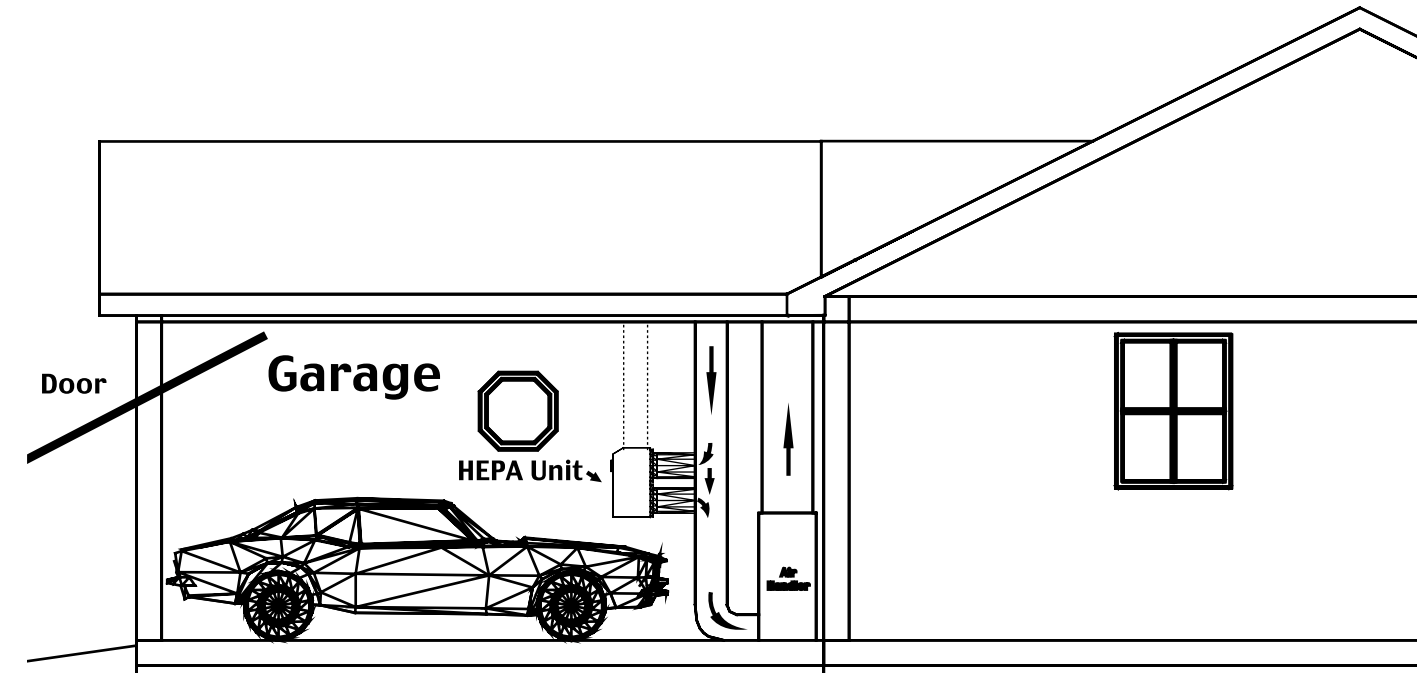

Option A – Garage installation

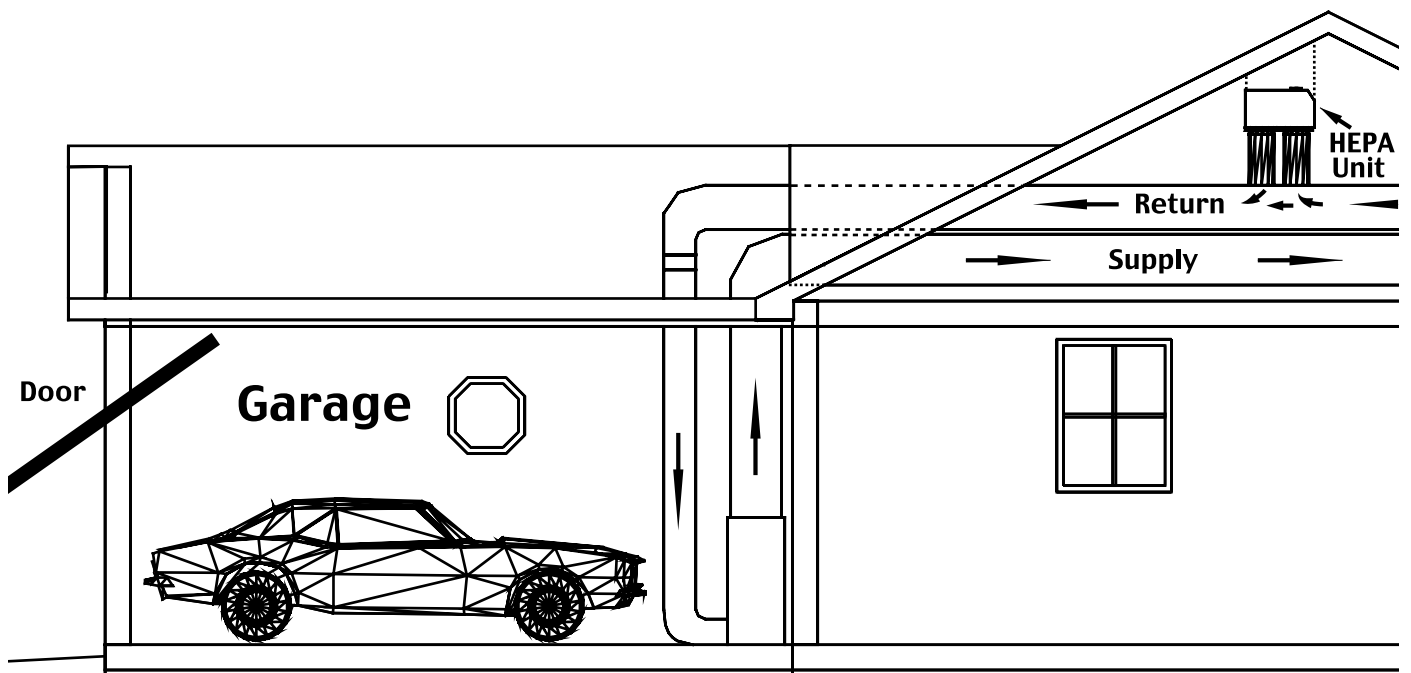

Option B – Attic installation connected to return of or handler

Installation (Cont'd)

CM 3000 I - Insulated model (continued)

* Diagrams are examples only. Actual installation may vary.

When unit is installed in an unconditioned space such as option C or option D, ductwork (not included) must be insulated and installed according to local and state codes.

Unit should always be installed in a location that will allow the best possible access for service. Flexible ducting can be restrictive to airflow and should be kept to a minimum. Avoid excessive turns, cramped ductwork and pinching.

*Proper airflow should be confirmed after installation

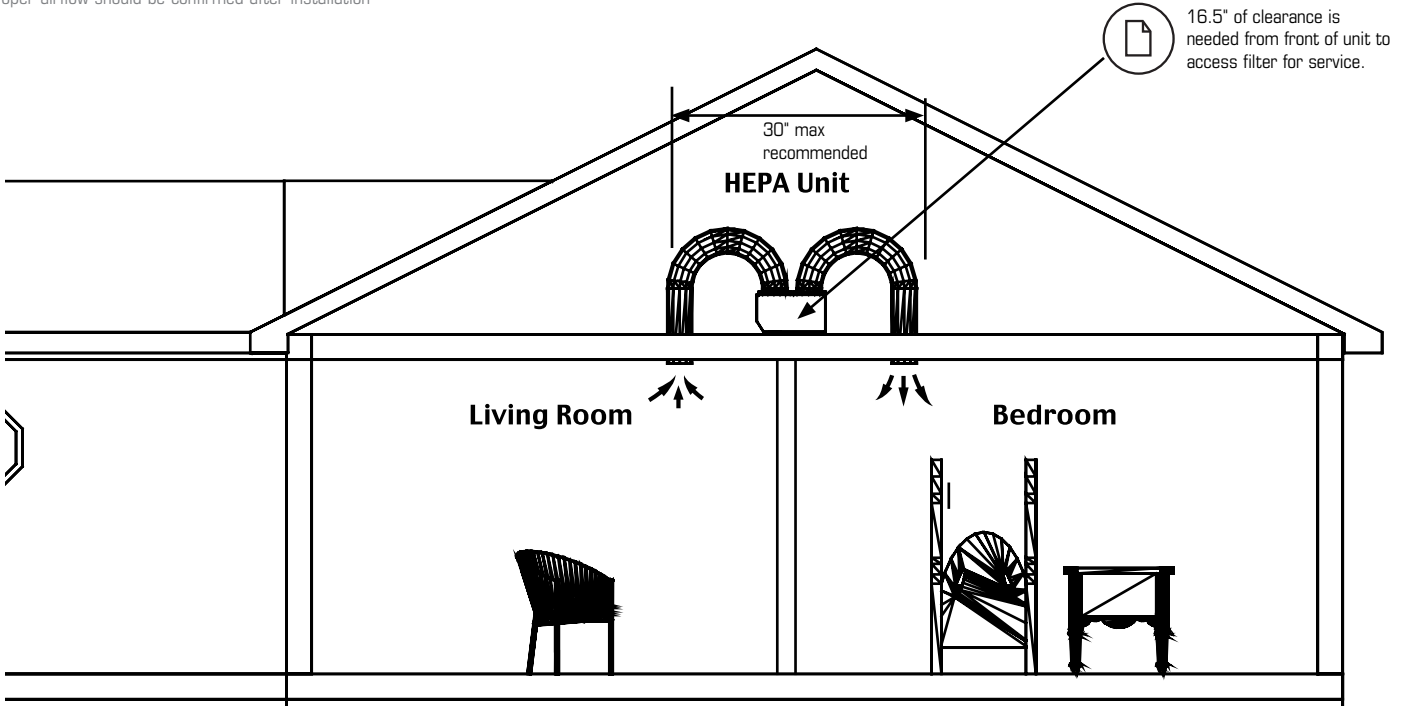

Option C – Independently ducted

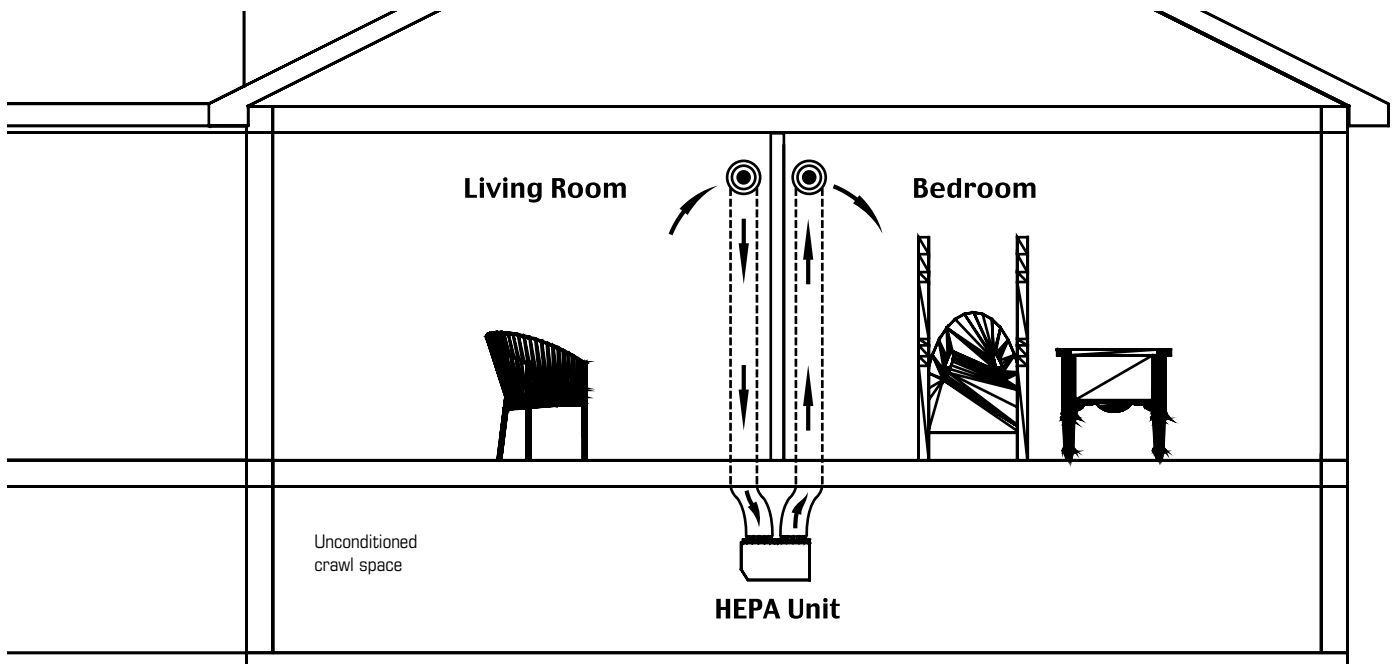

Option D – Independently ducted installation in crawled space

Installation (Cont'd)

Whole House – Connecting a ventilation system (HRV/ERV) to a HEPA system

* Diagrams are examples only. Actual installation may vary.

Installation may vary drastically from picture depending on location of all appliances. After installation, proper operation of all the appliances must be confirmed by a qualified contractor.

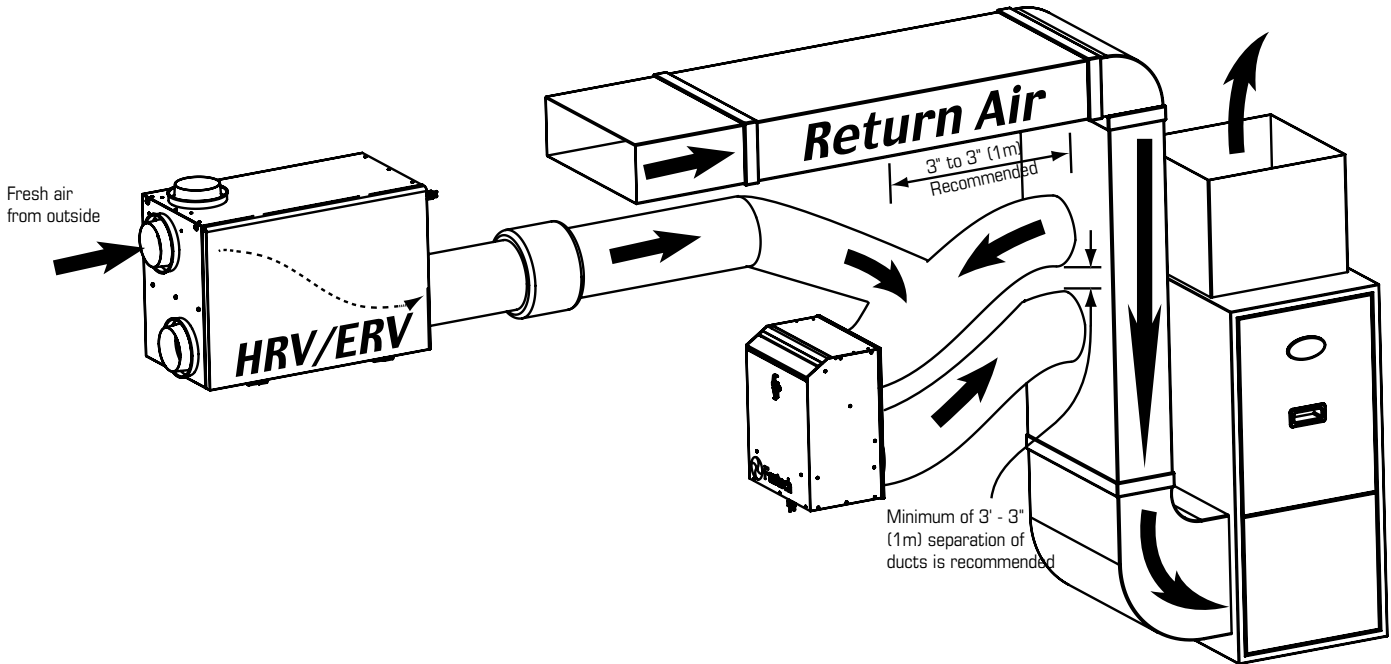

Ventilation system (HRV/ERV) should be installed and balanced in accordance with its installation manual.

Furnace fan must be on when either the ventilation system (HRV/ERV) or the HEPA filtration system is operating.

A power damper is recommended to prevent backdrafting of some models of air to air changers, when in the off or standby position. This damper will be installed between the HRV/ERV and the HEPA unit.



Models Flex100H, VHR100R, 70R, 150R, 1405R, 2005R, SHR1505R, 2005R & 3005R have an automatic backdraft damper build in that activates when units are in standby position and do not need this additional damper.

All units should be checked after installation for compatibility and proper operation.

Service

The useful service life of the filter media in the HEPA Filtration System is directly related to the volume of air passed through the system and the amount of contaminants in the air. In a typical residential application, Stage 1 and 2, filters should be replaced every three to six months or when needed. The Stage 3 HEPA filter should have a life span of two to five years, again, depending on the amount of particulate in the air and the maintenance of the Stage 1 pre-filter.

Parts list

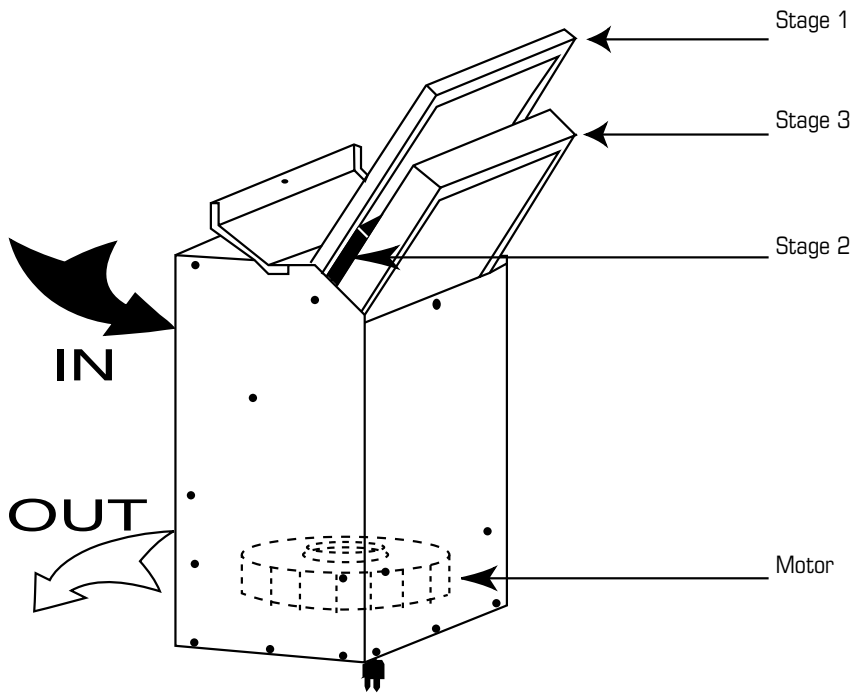

- Stage 1 - Prefilter: Air passes through the prefilter where larger particles are taken out of the air. (part number 40195, also available in packs of 24 part number 40196)
- Stage 2 - Carbon: Air passes through the carbon filter where some gases and odors are removed. (part number 40195, also available in packs of 24 part number 40196)
- Stage 3 - HEPA: Air passes through the certified HEPA media where very small particles are removed. 99.97% of all particles 0.3 microns and larger that pass through this stage are removed. Particles smaller than 0.3 microns are also removed with less intensity. (part number 40193, also available in packs of 12 part number 40194)

If the air flow through your unit is noticeably reduced, you can inspect the HEPA filter by removing it and seeing if the filter paper is darkened on the inlet or outer side. If it is, the filter cartridge should be replaced.

Please contact your local Fantech dealer or call HEPA Customer Service at 1.800.747.1762 regarding replacement of filter media, warranty information or if you have any questions or concerns about the performance of your HEPA Filtration System.

Replacement parts number for motor (40323) .

Warranty

- The maintenance free motors are permanently lubricated and are guaranteed for 7 years. They are factory balanced to prevent vibrations and promote silent operation.
- All other components have a 5 year limited warranty. (filters not included)
- The limited warranty covers normal use. It does not apply to any defects, malfunctions or failures as a result of improper installation, abuse, mishandling or misapplication, fortuitous occurrence or any other circumstances outside manufacturer's control.
- The warranty is in effect for 5 years on parts and 7 years on the motor after the date of purchase, including parts replaced during this time period. If there is no proof of purchase available, the date associated with the serial number will be used for the beginning of the warranty period. Parts are a 1 year warranty when replaced after the initial warranty has expired.
- This warranty is the exclusive and only warranty in effect and all other warranties either expressed or implied are invalid.
- Warranty from the manufacturer is for parts only and does not include labor or shipping to service or repair them.

Fantech reserves the right to make technical changes.
For updated documentation please refer to www.fantech.net

Fantech®

